

Lightweight module installation manual

Catalogue

1	Module User Manual.....	2
1.1	Disclaimer.....	3
1.2	Scope of responsibility.....	4
2	Preventive safety measure.....	4
2.1	Warning.....	5
2.2	General safety.....	5
2.3	Regular safety.....	6
2.4	Safety of electrical performance.....	6
2.5	Handling safety.....	7
2.6	Fire safety.....	8
3	Precautions for handing,storage and transportation.....	8
3.1	Turnover precautions.....	8
3.2	Storage precautions.....	9
3.3	Unloading mode and precautions	10
3.4	Project site transport	13
3.5	Secondary transport	15
4	Unpacking method.....	16
4.1	Notes.....	16
4.2	Unpacking safety.....	17
5	Introduction to installation method.....	19
5.1	Safety requirements.....	19
5.2	Regular requirements.....	20
5.3	Mechanical installation.....	20
5.3.1	Color steel tile installation.....	21
5.3.2	Flat glass installation.....	27
5.3.3	Glazed tile, cylinder tile surface installation.....	29

5.3.4	Cement flat EPS installation.....	31
5.3.5	Light installation.....	32
6	Electrical installation.....	32
6.1	Behavior of electricity.....	32
6.2	Cable and connection.....	34
6.3	Connector.....	35
6.4	Bypass diode.....	36
7	Landing.....	36
7.1	Lightweight modules ground.....	36
7.2	Other material grounding.....	36
8	Cleaning and maintenance.....	37
8.1	Cleaning.....	37
8.2	Appearance inspection.....	39
8.3	Connector and cable inspection.....	40
9	Release and execution.....	40

1 USER MANUAL INTRODUCTION

First of all, thank you for choosing our products! This manual contains relevant information and data in connection with the installation mode and safety operation of the photovoltaic modules (hereinafter referred to as "Module") manufactured by DAS Solar (Quzhou) Co., Ltd. . DAS Solar (Quzhou) Co., Ltd. is hereinafter referred to as "DAS Solar". Any violation of these safety instructions may lead to casualties or property loss.

Before Module installation, installation personnel shall go through and understand these instructions. Should you have any concerns, please contact the service department of DAS Solar or our local representative for further information. Installation personnel shall comply with all safety precautions set out in this manual, local requirements, and regulations of the law and authorized institutions. Prior to installation the solar photovoltaic system, installation personnel shall clearly understand its mechanical and electrical requirements. The operation of the photovoltaic system requires relevant expertise, and therefore the system installation and maintenance shall be performed by qualified personnel with professional skills and knowledge.

Please keep this manual in a secure place, and adopt it as the basis for operation, maintenance and servicing, or use it upon resale or disposal of the Modules. DAS Solar Modules pass the tests of global detection and certification institutions, and can be used safely provided that the requirements set out in the provisions of this manual are observed. Any Module installation operator shall notify the above requirements to the end users (or consumers).

1.1 Disclaimer

DAS Solar reserves the right to revise this manual without prior notice. If the customer fails to comply with the requirements set out in this manual during the installation process of the Module, the limited product warranty offered to the customer will be invalidated. This manual is of no significance to the warranty, whether explicit or implied. This manual doesn't contain any

information in relation to any compensation plans for any losses, Module damage or other costs arising from or in relation to the installation, operation, use and maintenance of the Module. DAS Solar disclaims any liability for any infringement on any patent rights or third-party rights arising from the operation or use of the Module.

1.2 Scope of responsibility

DAS Solar disclaims any liability for any following kinds of injuries and losses, including but not limited to any physical injuries or property losses resulted from Module misoperation Module, system installation failure, and violation of the instructions set out in this manual.

mandatory	Absolutely prohibited
 Otherwise it may cause product damage or endanger the personal safety of users	 Otherwise it may cause product damage or endanger the personal safety of users

2 Preventive safety measure

2.1 Warning

Please read and understand all safety rules prior to installation, wiring, operation or maintenance of the Module. Photovoltaic Modules may generate power energy when directly exposed to light sources, and a photovoltaic array comprised of multiple Modules may create dangers critical electric shock or burning, thus any person without authorization and related training shall not contact the photovoltaic Module and its wiring terminals, etc.

2.2 General safety

- ◆ The modules should be stored in the original packaging box before installation. Please protect the package from damage. Transport the modules and open the module package following the recommended mode of transport and unpacking procedure. To avoid damage to the modules, do not scratch or impact the modules. Do not press directly on the module during shipping. Improper transportation or installation may damage the modules and invalidate the warranty. Do not step or stand above the module box and the module.
- ◆ When hoisting components, the packing boxes should be placed upright, hoisted to the roof support beam nodes, unpacked immediately, spread face to face, and placed parallel to the support in the area to be installed or on idle pallets (do not place connector terminals on the ground). Unpacked components should not be placed on the roof for a long time.
- ◆ Work only in a dry environment, ensure that all modules and electrical contacts are clean and dry before installation; if you need to store uninstalled modules outdoors for a period of time, always cover the modules and keep the front down and placed on a soft surface to prevent internal water and damage to connectors;
- ◆ When unpacking, two or more personnel must operate at the same time, do not grasp the module junction box or lead wire to lift the module, please use the modules with both hands, do not overlap the module; do not place the modules in no reliable support or not fixed environment; do not place any heavy or sharp

objects on the module.

2.3 Regular safety

- ◆ DAS SOLAR lightweight module meets the application level II. Such modules can be used in systems that the public may contact with above DC 50V or 240W.
- ◆ When the modules is applied on the roof, the overall fire rating of the final structure shall be confirmed. The roof of the installed PV system must be evaluated by a construction expert or engineer, with formal complete structural analysis, and proven to withstand additional system support pressure, including the weight of the PV module itself.
- ◆ For your safety, please do not work on the roof without safety precautions including, but not limited to, fall protection, ladders or stairs and personal protection equipment. To ensure safety, do not install or handle modules in hazardous environments, including but not limited to strong winds or gusts, wet or sandy roofs.

2.4 Safety of electrical performance

- ◆ The installer must follow all safety precautions, local requirements, and legal or authorized agency regulations described in this guide. The operation of the photovoltaic system requires relevant professional knowledge, and it must be installed and maintained by qualified personnel with professional knowledge. Unauthorized and relevant trained personnel should not contact the photovoltaic modules and be close to the installation area or the module

storage area.

- ◆ It is forbidden to use damaged modules, and damaged modules should not be repaired without prior consent of DAS Solar , and contacting the surface of the modules may cause electric shock danger. Do not disassemble the module or remove any component of the module. Do not concentrate sunlight on these solar module.
- ◆ Make sure that the polarity of each module or string is not connected with the opposite of the other module or string. Make sure that there is no gap between the insulation washers of the joint, and that any gap between the insulation washers may cause a fire and / or electric shock risk.
- ◆ According to the national electrical code requirements, the maximum system voltage shall not exceed the certified maximum system voltage of the modules.
- ◆ Do not install or operate the module during the wet or windy condition. Install the solar modules with tape and structural silicone in sunny day.
- ◆ Broken junction boxes and broken connectors may generate potential electrical and scratch hazards. No damaged modules shall be used or disassembled.

2.5 Handling safety

- ◆ To avoid damage to the modules, do not scratch or press the modules or use paint or liquid place on the front sides of the modules. To avoid insulation problem, avoid scraping, cutting cables and connectors or prolonged exposure to sunlight. Do not drop any object on the module. Do not place any heavy

objects or sharp objects on the module.

- ◆ In case of a fire, the power supply should be disconnected firstly, and then the fire should be extinguished according to the fire fighting requirements.
- ◆ Only work in dry environments with dry tools. Do not operate in a wet environment without wearing any protection equipment. In sunlight, whether the photovoltaic module is connected to the system, do not touch the junction box, connector, cable and other active bodies of the module directly without any protection.
- ◆ Do not climb, trample, stand, walk or jump directly on packages or modules.
- ◆ Do not place the module face up on any platform.

2.6 Fire safety

Read local laws and regulations before installing modules and follow the building fire resistance requirements. According to the corresponding certification standards, DAS SOLAR lightweight module fire rating is Class C according to UL790 standard. Different structure and the Solar Photovoltaic Module on the roof will affect the fire safety performance of the building. Use appropriate modules such as fuses, circuit breakers, and ground connectors in accordance with local regulations. Do not use the module if an exposed combustible gas occurs in the vicinity.

3 Precautions for handing, storage and transportation

3.1 Turnover precautions

- ◆ Please use forklift to unload the Module from the truck (up to two trays of Modules at one time), and place the Module on the level ground..
- ◆ Do not stack the Modules in the project site, so as to prevent collision and damage.
- ◆ Please use rainproof fabrics to cover the Modules when they are pending for turnover for a long period so as to prevent dampness, and do not unwrap the packing.
- ◆ Packaged Modules can be transported through land transportation, sea shipping or air transportation, and make sure the module package is not rolling during transportation.
- ◆ Turnover In terms of general transport trucks, up to 2 levels of stacking can be allowed for Module transportation.
- ◆ When handling or installing the Module, do not support the Module through its back plate, avoid carrying the Module on the operator's back, and avoid use rope to carrying the Module.
- ◆ Do not use tricycle to transport the Module. As for transport in the project site, stacking is disallowed.

3.2 Storage precautions

- ◆ Prevent the modules from rain or damp. If you need to store the uninstalled modules outdoors for a period of time, always cover the modules and ensure that the lightweight module battery is unilateral down and placed on a soft







plane to prevent water inside the modules and damage to the connector.

- ◆ If the component needs to be transported for a long distance or stored for a long time, do not remove the original package of the component. Instead, use a waterproof rain cloth to protect the component from light.
- ◆ Pay attention to the weather conditions at the project site during installation. Avoid components with packing cases from being exposed to direct rain or direct sunlight outdoors. Take rain and light protection measures for packing cases.
- ◆ Warehouse storage (humidity <70%; temperature: -20°C ~ + 50°C): lightweight series module can stack up to 2 supports;

3.3 Unloading mode and precautions

When unloading the modules from the transport vehicle, use reasonable lifting tools for up to 2 supports once. Before lifting, confirm whether the tray and carton are damaged, skewed, and whether the lifted rope is strong and firm. When the lifting is fast to the ground, the carton on the relatively flat position of the project. Or use a forklift to lift the modules from the truck and place the unloaded modules on the level floor.

When the modules are stored in the project site briefly, place the modules in a ventilated and dry place, prohibit stacking the modules in the project site, cover the modules, and reinforce the rain cloth with cloth curtain or net belt to prevent the modules from damp and rain:

<p>Do not discard the modules at will</p> 	<p>Prevent modules from rain or damp</p> 	<p>Do not tread on the packing boxes and modules</p> 
<p>The modules in the carton are fragile items, which should be handled when handling</p> 	<p>The packaging shall be carried upward vertically during transport</p> 	<p>Do not exceed the maximum layer limit of printed signs on the outer box where modules</p> 

Hoisting and handling:

When unloading with hoist, please use specialized tooling, and adopt hoisting tools with sufficient tension according to the weight and size of the Module. During hoisting, please timely adjust the sling and keep the Module's gravity center steady. Please use a wooden board on the top of the packing case (its width shall be the same with the wooden board) or other fastening devices to prevent the sling from crushing the packing case and damaging the Module. Please operate the hoist in a steady rate, and when the hoist is approaching the ground, please hold the carton and gently secure it to a relatively level position.

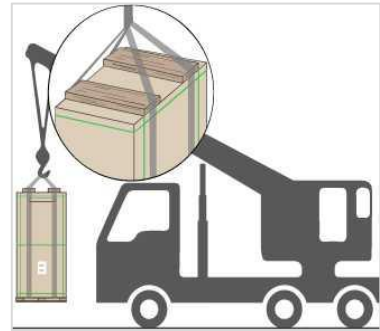

Please do not hoist the photovoltaic Module in any adverse weather conditions, such as strong wind greater than scale 6 (Beaufort scale), heavy snow or heavy rain. Up to 2 trays of modules are allowed for hoisting, in case of horizontal packing.

Forklift handling:

The height of the handling platform shall be on the same level with the carriage to the greatest extent, and the driving speed of the forklift shall be controlled within 5km/h upon straight running, and 3km/h upon steering. Emergency stop and start shall be avoided.

If the packing case shields the view of the forklift driver, the driver is advised to reversely run the forklift during the handling process, and a specialized person shall be assigned to monitor and provide guidance, so as to prevent collision with any persons or articles and avoid injury accidents or damage of the Module due to drop of the packing case. After transporting the packing case the installation site, please place it on the level and hardened ground.



General warehousing forklift:

Please use forklift with appropriate lifting capacity, according to the weight of the Module. The depth of the fork sticking into the tray shall not be less than three fourths of the tray length (length of fork not less than $LN3/4$ of tray length). It is advised to extend the height or width of the forklift load-backrest to prevent direct collision of the forklift with Module glass.

In order to ensure better stability of forklift operation, please make sure that the fork spacing shall be adjusted to the largest extent possible while avoiding collision with the two corners of the tray. Please slowly operate the forklift, and do not crush the carton or tray.

Please provide protective buffering materials beforehand (for the section highlighted in yellow in the figure, please use silicone, rubber, EPE or similar materials) to prevent damage of the Module inside the packing case due to external force.

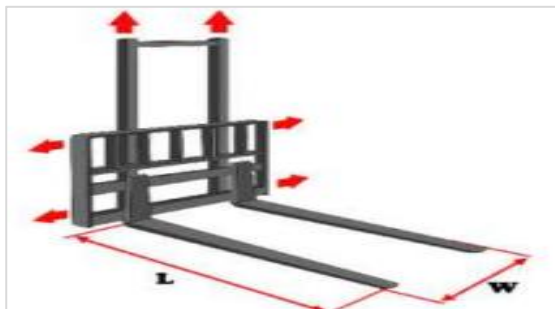

3.4 Project site transport

Project site transport refers to loading and transport of the tray-based Modules between from the storage site to the project site after the Modules arrive at the storage site.

Forklift specification requirement: Please uniformly use forklifts with the rated lifting capacity of N3.5t for loading and transfer of the Modules, and avoid direct contact of the fork protrusion with the cartons or Modules so as to prevent damage of the Modules due to collision.

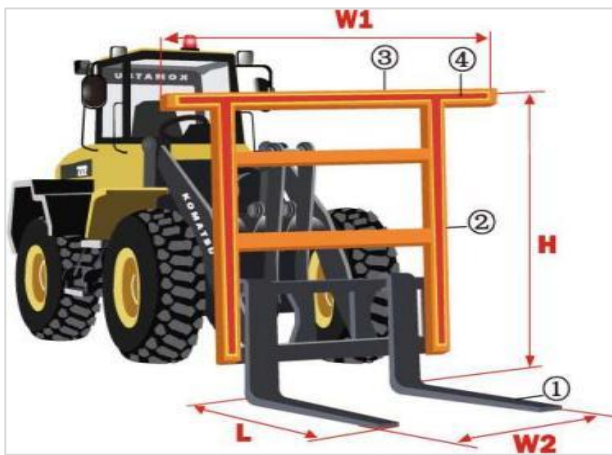

Fork length (L) shall be N1.0m, and fork interval (W2) shall be adjusted to approach the two corners of the tray to the greatest extent.

Gantry height (H) shall be N1.5m or gantry width (W1) shall be N2.5m.

The gantry shall be vertical to the fork, and the gantry structure shall be sturdy (able to bear the load of N1.5t). When the entire tray of Module is leaned on the gantry, the gantry shall not be deformed due to stress.

The injunction part of the top beam of gantry and the Module packing shall be protected with buffering materials (silicone, rubber, or EPE), to avoid damage of the Module and profiles.

The specification and operating specification of forklift include but not limited to the above information.



The driver shall operate the fork to slowly stick into the space baseplate and the panel from the long edge side of the tray, and avoid colliding with the Module, and make sure that both sides of the fork gantry are approaching simultaneously. When transporting the module with the forklift, lean the packing case onto the fork gantry, and make sure to fasten the Module with safety ropes featuring the tensile strength of N2000kgf. Upon loading with the forklift, first steadily place the packing case on the ground, then remove the safety ropes when the tilting risk is negligible. Control the driving speed of the forklift during transport, and slowly withdraw the fork when unloading, so as to prevent tilting.

3.5 Secondary transport

- ◆ If the modules require secondary long-distance transportation or long-term storage, removing the original packaging is prohibited. The packaged finished products can be transported by land, by sea, or by air.
- ◆ During transport, secure the box on the transport platform to ensure the package does not roll. Take land transport as an example, when normal truck

transport, up to two layers are stacked, prohibit cutting the packing belt.

- ◆ When the project is checked on site, the original packaging is not allowed, and only one layer of transportation is allowed. During the transportation, please fix the packaging box on the transportation platform to ensure that the packaging will not be dumped.
- ◆ .It is forbidden to use tricycle transfer modules, rope binding and back modules, single back modules, and forbidden to carry or drag the modules through the wire or junction box of the modules.
- ◆ When transported through small truck, the horizontal packing can't be allowed for stacking, and the Module must be fixed onto the trunk with safety ropes on the four sides, and the contact part between the safety rope and the carton must be isolated with corrugated paper or other buffering material. During the transport, the driving speed must be controlled according to road conditions.
- ◆ When transporting the Module through a van truck or non-van truck, different trays must be stuffed to leave no space, and any empty space at the rear of the van must be stuffed and reinforced to prevent the Module's movement to the rear during transport. When transporting the Modules through a non-van truck, each tray of Modules must be fixed onto the transport vehicle with safety ropes.
- ◆ The tray must be placed within the loading area of the transport vehicle.

4 Unpacking method

4.1 Notes

- ◆ Before unpacking, please check the product name and serial number on the outer box A4 paper, and the custom unpacking method is prohibited.
- ◆ When unpacking, cut all vertical packing belts with blades or scissors, first the long belt and then the short belt; remove the upper cover of the carton and remove two or three upper lifting supports.



- ◆ When removing the module from the box, two people must stand on both sides of the box, and hold the module, one hand grasping the corner, the other one grasping the short side, and remove the module.
- ◆ If unpacking on horizontal ground, remove the module from one side to the other side and carry it. If unpacking on non-horizontal ground, use the supporting dismount tool to prevent the module side dumping.



- ◆ The modules removed from the packing box shall not be placed inclinedly on the mounting post and in an environment without reliable support or fixation.

4.2 Unpacking safety

- ◆ In windy weather conditions, please do not handle the Modules, and properly secure and fix any unpacked Modules.
- ◆ Do not move the leaning posts during the unpacking process, so as to prevent tilting of the Modules.
- ◆ Do not carry out outdoor unpacking operations in harsh weather conditions such as rain and snow.
- ◆ Prior to removing the inner packing straps, please carry out proper protection to prevent tilting of the whole unit of Modules.
- ◆ The operation ground shall be able to ensure that the packing case is steadily placed and tilting is avoided.
- ◆ Do not lean the Module on the installation post. Do not use wooden strips or other items to directly contact and support the rear side of the Module.
- ◆ Do not handle the Module by a single operator, so as to avoid scratches, deformation or cracks of the Module due to sliding and collision of the Module with other Modules. When lifting the Module, do not pull the wiring box or cables to withdraw the Module.
- ◆ Please carry out the operation in strict accordance with the requirements of unpacking instructions. When removing the packing straps of horizontal packing, please provide protective measures to avoid scratching your face or eyes, and avoid standing on the tray during unpacking, but handle the Modules from the two sides of the tray.

5 Introduction to installation method

5.1 Safety requirements

- ◆ DAS SOLA Rand lightweight series of modules has been IEC certified, and the life-expired photovoltaic modules need to be reasonably disposed of in accordance with local laws and regulations.
- ◆ Do not remove the module package and keep the module in the carton before installation.
- ◆ When installing modules, you can only work in a dry environment and use only dry tools. Do not operate in a wet environment without wearing any protection measures. Do not install modules under rain, snow, or high wind. Keep the connector dry and clean when installing the modules to avoid electric shock risk. If the terminal of the module is wet, it is impossible to avoid electric shock. Please install it immediately after the unpacking.
- ◆ During module installation and wiring, use opaque materials to completely cover the module and prevent electrical loss. Do not disconnect the electrical connection or unplug the connector if the circuit is loaded. Do not touch modules unnecessary after installation; module surfaces may produce high temperatures; and hazards of burns and electric shock.
- ◆ When installing modules, do not work alone and keep working teams of 2 or more people.
- ◆ After the module is installed, the cable should be fixed or tied, so that it will not be exposed to direct sunlight to prevent the cable from aging. Low-hanging

cables may cause various problems, such as leakage of water and fire.

- ◆ DAS SOLA lightweight module can be applied to Class II.

5.2 Regular requirements

- ◆ Lightweight modules are suitable for bonding to the clean, dry, unweathered color steel tile, color steel plate roof, need to meet the support requirements of the scene and the minimum requirements of direct paste. The recommended installation Angle is 0°-90°, and the installation direction facing the sun.
- ◆ The roof for lightweight modules should be smooth and wrinkle free. Should avoid the irregular areas and depression areas on the roof during the adhesion to the roof process that may lead to the deformation of the lightweight module surface.
- ◆ Clean the mounting substrate to be adhered before bonding the module, and wipe it with a clean fiber-free cloth or paper towel to make the roof completely dry. Make sure that there is no debris, talc, dust, oil, ice, snow, moisture and other debris, which will reduce the bonding effect and shorten the service life of the paste material.
- ◆ The installation surface has rust stains, need to use steel brush, sandpaper to remove rust, industrial rust paint treatment before drying.
- ◆ DAS SOLAR lightweight module passes a 2400Pa test load.

5.3 Mechanical installation

DAS SOLAR lightweight module uses neutral silicone structural adhesive

combination as the paste material, double-sided tape to assist positioning. Great for color steel tile houses Top installation.

Note: Structural adhesive make: Jiangshan Daqin New Material Technology Co Ltd ; Structural adhesive model: JGW-999

5.3.1 Color steel tile installation

A Confirm the color steel tile material, dimensions and appearance features

Color steel tile material: color PE coated steel plate coated on the surface of galvanized, aluminous, tin plated or cold rolled steel plates Size and appearance characteristics of color steel tile: trapezoidal color steel tile, corner-type color steel tile (additional rail installation, support spacing 240mm), upright lock edge color steel tile (additional rail installation, support spacing 240mm)

Color steel tile type	Ladder color steel tile	Horn chi type color steel tile	Vertical lock edge color steel tile
Corrugated width (mm)	≥15	≥3	≥3
Corrugated spacing (center spacing: mm)	≤240	≤430	≤488

B .Prepare the corresponding paste material

No.	Construction temperature condition	Paste material	Locating material	Tape specification
1	0°C < T ≤ 5°C	Neutral silicone structural adhesive	Double-sided pressure sensitive tape	Acrylic acid, thickness 2mm

2	$5^{\circ}\text{C} < T < 30^{\circ}\text{C}$	Neutral silicone structural adhesive	/	/
3	$T \geq 30^{\circ}\text{C}$	Neutral silicone structural adhesive	Double-sided pressure sensitive tape	Acrylic soft adhesive, thickness $\geq 2\text{mm}$

The maker and product type of tested neutral silicone structural adhesive as below for your reference. You need to purchase the adhesive from your local market according to the provided information. If this type is unavailable at local market and you can get some similar Neutral silicone structural adhesive from other supplier from the market, you can use it in the installation also after getting approval from DAS solar. Use of other neutral silicon structural adhesive without approval from DAS Solar will void product warranty.

Note: Structural adhesive make: Jiangshan Daqin New Material Technology Co Ltd ; Structural adhesive model: JGW-999

C Prepare the corresponding support rail material

Installation schematic diagram of guide rail-1

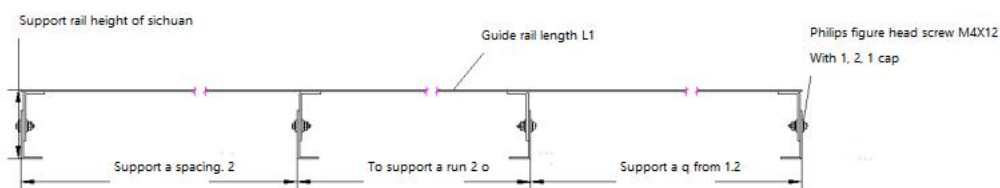

Length of guide rail-2

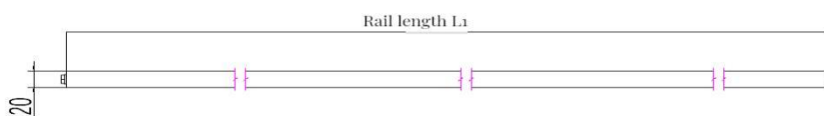

Support diagram-3

Support installation details-4

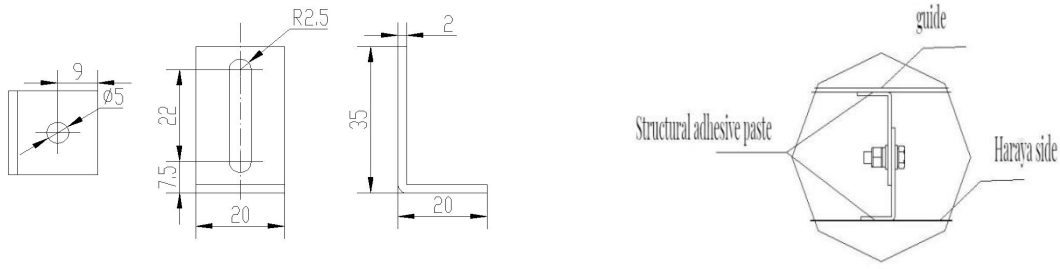

module model	Guide rail length: L1 (mm)	Number of support supports (PCS)	Support bracket spacing: L2 (mm)	Support rail height H1
DAS-LOJP	1985	4	661	Color steel tile valley peak to the valley floor height

D Light component pasting - vertical pasting

both sides of the relative support are equally arranged, under different construction temperature conditions, the paste diagram and construction mode selection reference table is as follows:

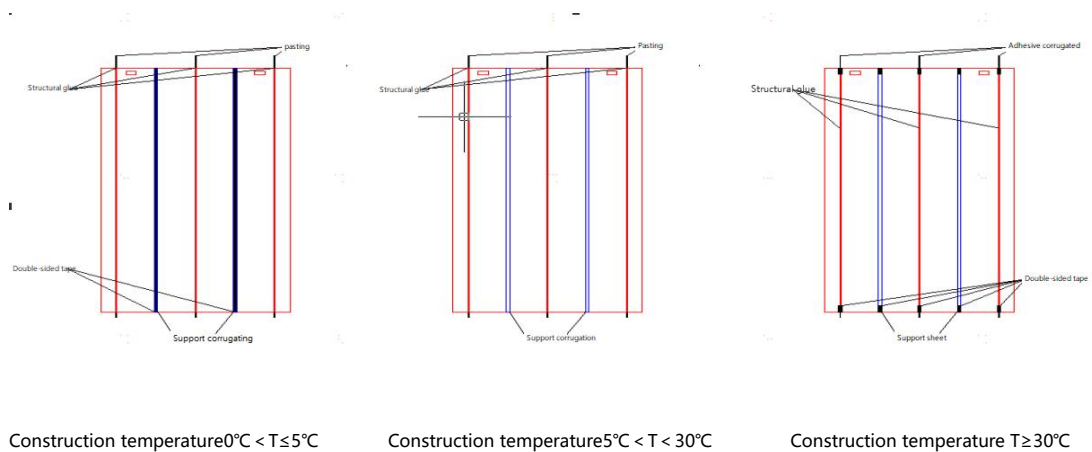

Construction temperature $0^{\circ}\text{C} < T \leq 5^{\circ}\text{C}$

Construction temperature $5^{\circ}\text{C} < T < 30^{\circ}\text{C}$

Construction temperature $T \geq 30^{\circ}\text{C}$

module	Construction temperature	Paste mode	Double-sided tape selection	Structural adhesive L1		Double-sided adhesive L2	
				L (mm)	Number (piece)	L (mm)	Number (piece)
DAS-LOJP	$0^{\circ}\text{C} < T \leq 5^{\circ}\text{C}$	Paste corrugated structural adhesive, Double sided tape for support	Acrylic tape: $T*W=2.0\text{mm}*20\text{mm}$	1985	3	1985	2
	$5^{\circ}\text{C} < T < 30^{\circ}\text{C}$	Paste corrugated structural adhesive	No paste	1985	3	0	0
	$T \geq 30^{\circ}\text{C}$	Paste corrugated structural adhesive, Double	Nano double-sided tape: $t*w=2.0\text{mm}*20\text{mm}$	1885	3	50	10

		sided tape for support					
--	--	------------------------------	--	--	--	--	--

Notes:

- 1、 Support center spacing $\leq 240\text{mm}$; When the distance between support centers is greater than 240mm, add support guide rails to meet installation requirements.
- 2、 According to the construction temperature conditions, according to the construction method selection reference table, construction and installation.
- 3、 Light components are placed in the area to be installed (do not place the connector terminals directly on the ground). The installation quantity is not greater than 24 hours.
- 4、 The above pasting method is suitable for a new energy lightweight component DAS-LOJP-xxx.

E Lightweight module -mount vertically

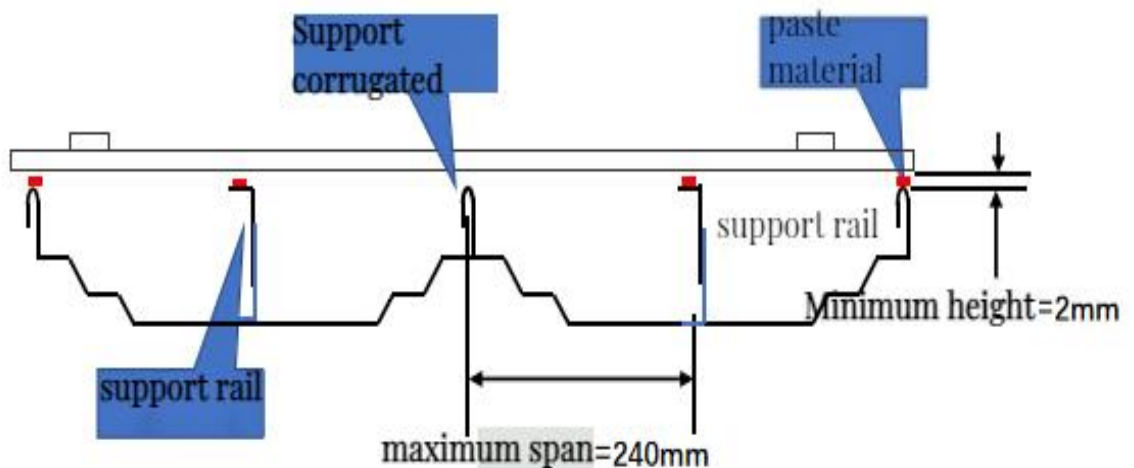

module type	Ladder color steel tile Support corrugated number (Pcs)	Horn chi type color steel tile Support corrugated number (Pcs)	Vertical lock edge color steel tile Support corrugated number (Pcs)
DAS-LOJP	≥6	≥5	≥5

F Lightweight modules - vertical arrangement

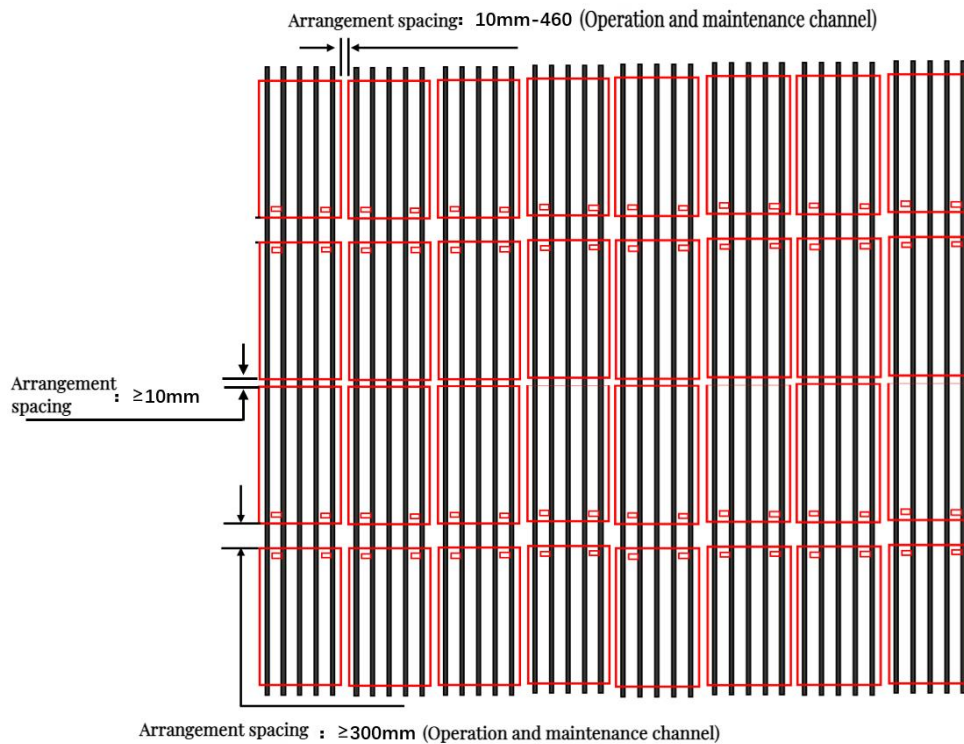

1.The long side of the module is parallel to the color steel tile valley peak corrugated installation, and the module gap should be 10mm to avoid dust between the modules.

2.The layout design shall reserve a 300mm wiring channel to facilitate the

system connection.

3.The cable shall not block the battery area of the front side of the module.

4.The overall module requires no shadow shielding. If the installation surface has shadow shading, the design should be reserved according to the actual shadow length.

5.3.2 Flat glass installation

A Confirm glass plan roof, dimensions and exterior features

B Prepare the corresponding paste material

No.	Paste material	specifications
1	Double-sided pressure-sensitive adhesive tape	Acrylic acid, thickness \geq 2mm
2	Neutral silicone structural gel	Single component

when the installation surface is TPO roof, it needs to be matched with the primer and pasted with the adhesive material. You can contact the order salesperson of DAS SOLAR to obtain supplier information.

C Module paste

Operating Steps: Convenient and reliable operation, "one clear, two fixed, three viscose, four installation, five roller pressure fit";

Installing form: It can be installed horizontally and vertically along the direction of water flow on the building roof.

Lateral installation: pressure-sensitive adhesive tape specification 20mm * 2mm

+ running water direction upper end and both sides of the edge structure glue sealing glue protection

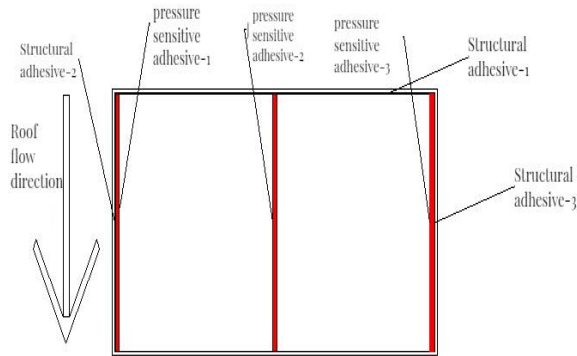

- 1、 pressure sensitive adhesive tape:**
Three equal paste, specification 20mm * 2mm, length and aluminum foil on the back of the assembly;
- 2、 structural adhesive:**
Close to the outer edge of the tape * 3, length and module length, glue width * height $\geq 6 * 2\text{mm}$;

Longitudinal installation: pressure sensitive tape specification 20mm * 2mm + water direction upper end and both sides edge structure glue protection

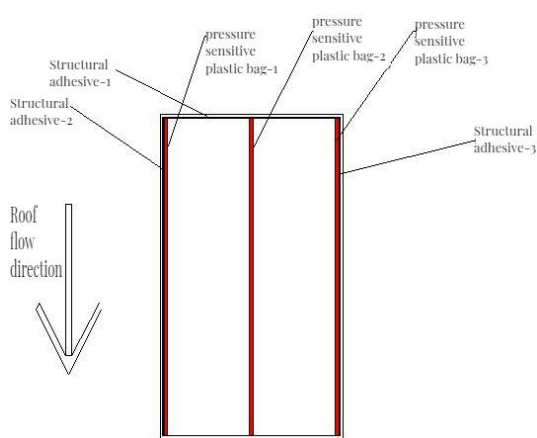

- 1、 pressure sensitive adhesive tape:**
Three equal paste, specification 20mm * 2mm, length and aluminum foil on the back of the assembly;
- 2、 structural adhesive:**
Close to the outer edge of the tape * 3, length and module length, glue width * height $\geq 6 * 2\text{mm}$;

D lightweight modules-Horizontal layout

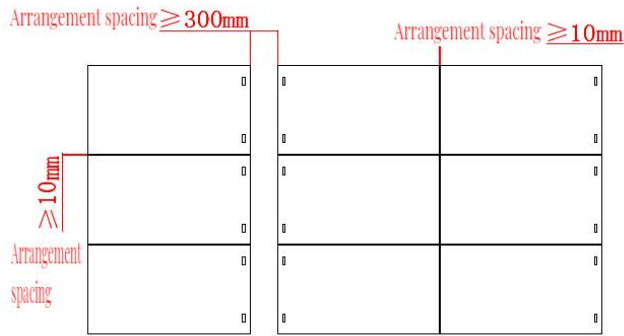

- 1、Meet the layout spacing of head wire box end $\geq 300\text{mm}$,
- 2、The spacing between the tail and the internal arrangement of the array is $\geq 10\text{mm}$,
- 3、Adjust it according to the actual situation of the installation surface

E lightweight modules-Vertical layout

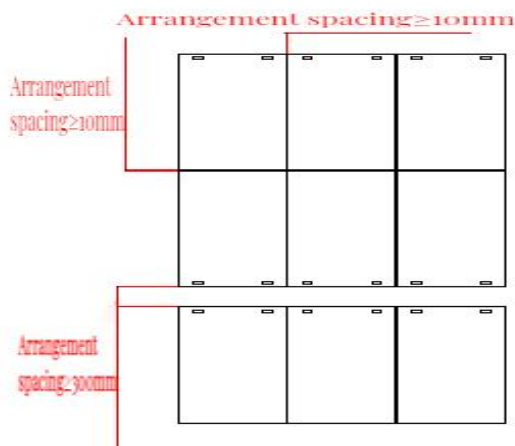

- 1、Meet the layout spacing of head wire box end $\geq 300\text{mm}$,
- 2、The spacing between the tail and the internal arrangement of the array is $\geq 10\text{mm}$,
- 3、Adjust it according to the actual situation of the installation surface

5.3.3 Glazed tile, cylinder tile surface installation

A Confirm tile roof, dimensions and exterior features

B Prepare the corresponding paste material

No.	Paste material	specifications
1	Double-sided pressure-sensitive adhesive tape	Acrylic acid, thickness $\geq 2\text{mm}$
2	Neutral silicone structural gel	Single component

C Module paste

Operating Steps: Convenient and reliable operation, "one clear, two fixed, three

viscose, four installation, five roller pressure fit";

Installing form: It can be installed horizontally and vertically along the direction of water flow on the building roof.

Lateral installation: pressure-sensitive adhesive tape specification 20mm * 2mm + running water direction upper end and both sides of the edge structure glue sealing glue protection

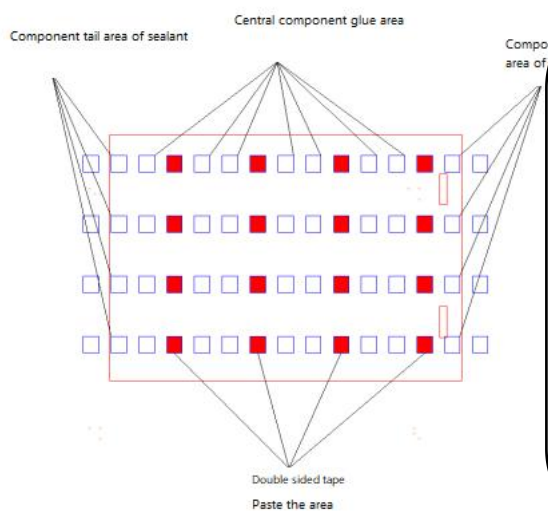

1. Pressure sensitive tape:

When the roof Angle is more than 20°, double-sided adhesive auxiliary paste fixed, double-sided adhesive station paste position is the tile crest along the bottom of the high convex point, tape point ≥ 36 (double-sided adhesive length: 80mm);

2. Structural adhesive:

Head and tail gluing area "double layer, double strip", central gluing area "single layer, double strip", gluing position corresponding to corrugated wave peak convex gluing, gluing width * height $\geq 6*2\text{mm}$;

Longitudinal installation: pressure sensitive tape specification 20mm * 2mm + water direction upper end and both sides edge structure glue protection

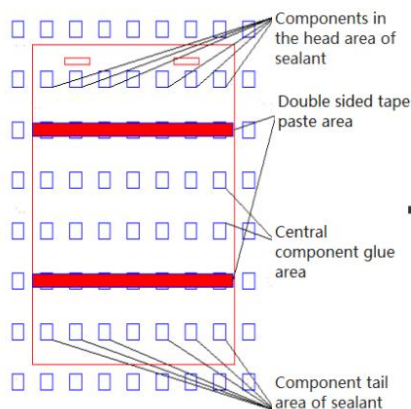

1. Pressure sensitive tape:

When the roof Angle is more than 20°, the double-sided adhesive auxiliary paste fixed, double-sided adhesive station paste position is the tile crest along the bottom of the high convex point, the number of tape ≥ 2 (double-sided adhesive length and component width);

2. Structural adhesive:

Head and tail gluing area "double layer, double strip", central gluing area "single layer, double strip", gluing position corresponding to corrugated wave peak convex gluing, gluing width * height $\geq 6*2\text{mm}$;

5.3.4 Cement flat EPS installation

A Confirm cement flat roof, dimensions and exterior features

B EPS Installation mode

No.	module type	EPS Dip Angle	EPS specification	adhesive	Structural adhesive
1	DAS-LOJP	5°	EPS1-1985*70* (150.1/144.0) mm EPS2-1985*70*(117.6/111.5) mm EPS3-1985*50*(85.1/80.8) mm EPS4-1985*50*(54.3/50) mm	EPS The underside of the module is fully coated	(Outer & middle) Glue and component length equal *4

C Module installation

Operating Steps: Installation surface cleaning, positioning marking, adhesive mixing, adhesive coating, EPS module installation, positioning gluing, component installation

Lateral installation: Pressure sensitive tape specifications 20mm*2mm+ the upper end of the water direction and the two sides of the edge structural adhesive sealant protection.

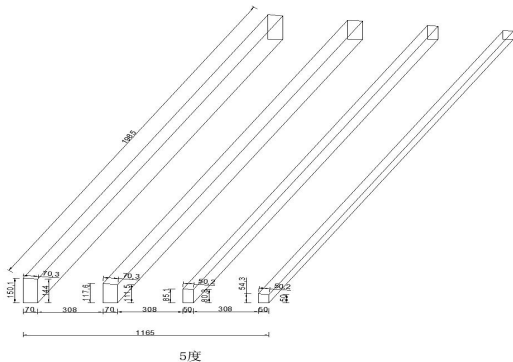

Structural adhesive:

Glue *4 evenly in the middle of EPS, the length of the rubber strip is equal to the long side of the component, the width of the rubber type * height $\geq 6*2\text{mm}$;

For lightweight products confirm the materials and building roof types above,

the materials and building roof types not in the list, please contact the Product Development Department for relevant evaluation.

6 Electrical installation

6.1 Behavior of electricity

- ◆ The nominal values of the electrical performance parameters of the modules such as I_{sc} , V_{oc} , and P_{max} are associated with a $\pm 3\%$ error under the standard test condition. Standard test conditions of modules: irradiance 1000 W / m^2 , battery temperature 25°C , air quality AM1.5.
- ◆ When the modules are connected into a string, the final voltage is the sum of single modules, when the modules are in parallel, the final current is the sum of single modules, and the modules of different electrical performance models cannot be connected in a string.

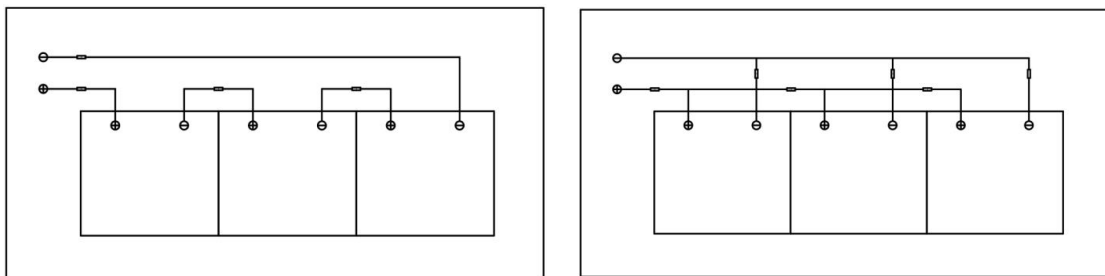

Series connection

parallel connection

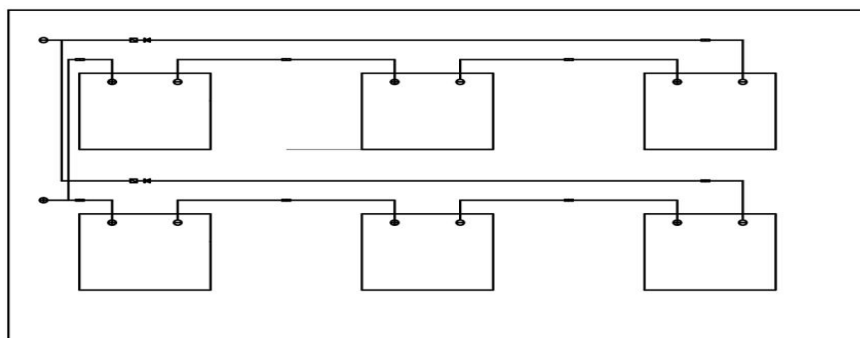

Series after parallel connection



Figure 1 Electrical diagram of series and parallel lines

- ◆ The maximum number of single string modules that can be connected in series must be calculated according to the relevant requirements. The open circuit voltage at the local expected minimum temperature conditions cannot exceed the maximum system voltage (DAS SOLAR lightweight module is DC1500V-the actual system voltage is designed according to the selected module model and inverter) and other DC modules. That is, the open circuit voltage of a single component (VOC at the local expected temperature)* Number of components \leq 1500V system voltage. Taking DAS-LOJP-420 as an example, under STC conditions, its open circuit voltage is 50.45V, and the maximum number of single string components in series is $\leq 1500/50.45=29.73$ to prevent voltage fluctuations, rounded down to 29 blocks.
- ◆ The open-circuit voltage correction factor can be calculated from the following formula: $C_{Voc}=1-Voc (25-T).T$ is the minimum ambient temperature expected at the system installation location, and β (% / °C) is the temperature coefficient of the selected module Voc (see the corresponding module parameter table).
- ◆ If there may be a reverse current exceeding the maximum fuse current passing through the module, the same specification of overcurrent

protection device must be used to protect the module. If the number of parallel connections is greater than or equal to 2 strings, there must be an overcurrent protection device on each string module, as shown in Figure 1.

6.2 Cable and connection

- ◆ Connections of modules shall be made with an IP68 protection grade junction box, which shall provide safety protection for conductors and their corresponding connections, and accessible protection for non-insulated live parts. The junction box consists of connected cables and IP68 protection grade connector to facilitate series between modules. A single module has two wires connected to the junction box, including a positive electrode and a negative electrode. The two modules can be connected in series by inserting the positive interface at the other end of a module wire into the socket of the negative wire of an adjacent module.
- ◆ Use dedicated solar cables under local fire prevention, building and electrical codes with suitable connectors (wires should be covered in anti-aging tubes and themselves if exposed to air) and ensure good electrical and mechanical performance of the cables.
- ◆ Installers can only use single wire solar cables, 2.5-16mm² (5-14 AWG), 90°C rating with appropriate insulation to withstand the maximum possible system open circuit voltage (as approved by EN50618). Appropriate wire specifications need to be selected to reduce the voltage drop.

- ◆ DAS SOLAR requires all wiring and electrical connections to meet the corresponding National Electrical Code.
- ◆ When the cable is fixed to the bracket, you need to avoid mechanical damage to the cable or modules. Do not press the cable hard. The cable shall be fixed to the bracket by specially designed aging-resistant cables and wire cards. Although the cable is aging-resistant and waterproof, but also to avoid direct sunlight and rain immersion.
- ◆ The minimum bending radius of the cable shall be 41.5mm.

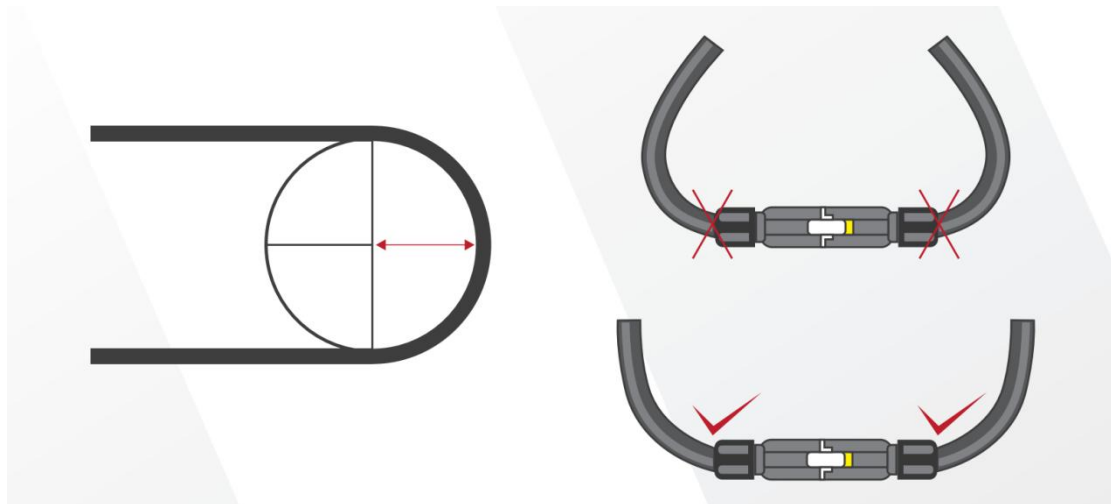

6.3 Connector

- ◆ Keep the connector dry and clean, and make sure the connector nut is fastened before connecting. Do not connect the connector if it is wet, dirty, or otherwise unfavorable. If the connector is not positive or negative connected, the connector is not waterproof. The modules should be connected as soon as possible, or appropriate measures should be taken to avoid infiltration of water vapor and dust. Avoid direct sunlight and

immersion in water. Avoid connectors from falling on the ground or roof.

- ◆ The wrong connection may generate arcs and shocks. Please make sure that all the electrical connections are strong. Ensure that all connectors with locks are fully connected.
- ◆ Different models of connectors are not recommended to connect together (please contact DAS SOLAR).

6.4 Bypass diode

The battery string in DAS SOLAR module is protected by bypass diodes in parallel and packaged in the junction box. When a local hot spot occurs in the module, the diode will start working, so that the main current no longer flows through the hot spot cell, thus limiting the heating and performance loss of the module. Note that the bypass diode is not an over current protection device.

When the diode determines or suspects that a problem has arisen, ask the installer or system maintenance provider to contact DAS SOLAR. It is strictly forbidden to try to open the junction box of the module.

7 Landing

7.1 Lightweight modules ground

DAS SOLA lightweight photovoltaic module, without a metal bezel, so the product is not be grounded.

7.2 Other material grounding

The grounding system of the bridge or inverter frame of the roof lightweight

modules uses the original lightning protection grounding system of the building. The grounding resistance is less than $4\ \Omega$, which requires to be measured on site. If the requirements are not met, the artificial grounding pole will be added outside the building until the requirements are met.

Artificial grounding uses 2.5m long 5 horn steel as vertical grounding body, and 25 * 4 hot dip galvanized flat steel is reliably connected between angle steel.

Lay a circle of 25 * 4 hot-dip galvanized flat steel around the array as a lightning protection grounding network. During construction, if the requirements are not met, continue to add manual grounding pole until they meet the requirements.

8 Cleaning and maintenance

8.1 Cleaning

- ◆ The solar module produces electricity in proportion to the light that falls on it. Batteries with blocked modules generate relatively little power, so it is important to keep them clean.
- Photovoltaic modules shall be cleaned with irradiance below $200\text{W} / \text{m}^2$ to avoid different water temperature and air temperature; the modules shall be softened and the residual water on the module surface shall be dried.
- It is strictly prohibited to clean photovoltaic modules under meteorological conditions with wind force greater than level 4, heavy rain or heavy snow.
- When cleaning the surface of the module with pressure water flow, the water pressure used shall not exceed 70 KPa, and the module is strictly prohibited to bear additional external force.
- Photovoltaic module cleaning work, it is strictly prohibited to trample the

module, water splashing to the back of the module and the cable, ensure connector cleaning and drying to prevent electric shock and fire hazard; use steam cleaner; when cleaning modules, use soft cloth or soft roller and water to clean, do not put the modules directly into the water. Be careful to avoid serious thermal impact that may damage the modules.

- The surface of photovoltaic modules has oil and other difficult to clean substances, the use of frictionless neutral liquid detergent, can not use organic solvents containing alkali, acid to clean the module. Do not use corrosive solvents or wipe the photovoltaic modules with hard objects.
- If you are not sure if you need to clear the array or section, first select a column of particularly dirty array to start clearing. If the percentage is less than 5%, cleaning is usually unnecessary. The above verification should be conducted only with a constant sunshine rate (sunny days, strong sunshine and cloudless sunshine).
- The back of the module is usually not clean; if the back, avoid the cleaning fluid into the bottom of the material.
- Vegetation should be cut back regularly to avoid vegetation shielding the photovoltaic modules.
- Water quality requirements:
 - PH: 5 ~7;
 - Chloride or salt content: 0-3,000 mg / L
 - Turbidity: 0-30 NTU

- Conductivity: 1500~3000s / cm
- Total dissolved solids: 1,000 m g / L
- Water hardness: 0-40 mg / L
- Non-alkaline water must be used, and softened water must be used when available.

8.2 Appearance inspection

The modules in the photovoltaic square array should be regularly checked for damage. If any damage is found, the same type of modules should be replaced, such as module rupture, cable damage, junction box damage and other factors leading to functional and safety failure of the modules.

- Well-designed solar systems require minimal maintenance, but simple steps can be taken to improve system performance and reliability.
- It shall be maintained at least once every six months by trained personnel who shall wear rubber gloves and insulating boots to remove any shielding that may shield the solar modules and affect their performance.
- Check that the installed hardware is fastened in place.
- Check for the proper operation of all the array fluds in each non-ground pole.
- If the module is damaged, it needs to be replaced modules must be replaced with the same type. Do not touch the live parts of the cable and the connector when replacing the module. Use appropriate safety guards (insulation tools,

insulating gloves, insulation boots, etc.).

- When replacing the module, never remove the structural glue, then clean the adhesive with cleaning solvent, and connect the adhesive according to the module installation method.
- Repair with opaque material over the front surface of the module. Sun-exposed modules produce high voltage and are extremely dangerous.
- DAS SOLAR photovoltaic module junction box is equipped with a bypass diode, which minimizes the module heating and current loss.

8.3 Connector and cable inspection

- ◆ Check all cables to verify strong connection; one recommended all cables shall operate in suitable line and located away from easy areas.
- ◆ It is recommended to check the electrical, ground and mechanical connections every 6 months to ensure they are clean, safe, without damage and rust; the fittings are properly tightened; check all cables to ensure the joints are fastened.

9 Release and execution

The document is centrally managed by the Product Development Department of DAS Solar , and the final implementation and interpretation are in the responsibility of the Product Development Department